

### GENERAL DESCRIPTION

The SGM03HB1AJ is designed to protect voltage sensitive components from ESD. Excellent clamping capability, low leakage, high peak pulse current handling capability and fast response time provide best in class protection on designs that are exposed to ESD.

The SGM03HB1AJ is available in a UTDFN-1×0.6-2AL package with working voltage of 3.6V (MAX) and specifically designed to power lines protection.

### FEATURES

- High Capacitance
- Surge Protection Device
- Protection for the Following IEC Standards:
  - ◆ IEC 61000-4-2: ±30kV (Air)
  - ◆ IEC 61000-4-2: ±30kV (Contact)
  - ◆ IEC 61000-4-5 (Lightning): 30A (8/20µs)
- Bidirectional ESD Protection of One Line
- Working Voltage: 3.6V (MAX)

### APPLICATIONS

Power/Battery Line Protection  
 Audio and Video Equipment  
 Computers and Peripherals  
 RF PA Protection  
 Microphone Line Protection

### ABSOLUTE MAXIMUM RATINGS

PARAMETER	SYMBOL	VALUE	UNITS
Peak Pulse Current ( $t_p = 8/20\mu s$ )	$I_{PP}$	30	A
ESD IEC 61000-4-2 (Air)	$V_{ESD}$	±30	kV
ESD IEC 61000-4-2 (Contact)		±30	
Operating Temperature Range	$T_J$	-40 to +125	°C
Storage Temperature Range	$T_{STG}$	-55 to +150	
Lead Temperature (Soldering, 10s)		+260	°C

Stresses exceeding those listed in Maximum Ratings may damage the device. If any of these limits are exceeded, device functionality should not be assumed, damage may occur and reliability may be affected.

### PRODUCT SUMMARY

$V_{RWM}$ (MAX)	$I_{PP}$ (MAX)	$C_{IN}$ (TYP)
3.6V	30A	45pF

### PIN CONFIGURATION

(TOP VIEW)



UTDFN-1×0.6-2AL

### EQUIVALENT CIRCUIT



## PACKAGE/ORDERING INFORMATION

MODEL	PACKAGE DESCRIPTION	SPECIFIED TEMPERATURE RANGE	ORDERING NUMBER	PACKAGE MARKING	PACKING OPTION
SGM03HB1AJ	UTDFN-1x0.6-2AL	-40°C to +125°C	SGM03HB1AJXUEZ2G/TR	04X	Tape and Reel, 10000

## MARKING INFORMATION

NOTE: X = Date Code.

YY X

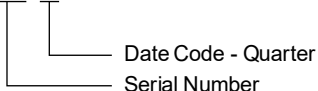

Green (RoHS & HSF): SG Micro Corp defines "Green" to mean Pb-Free (RoHS compatible) and free of halogen substances. If you have additional comments or questions, please contact your SGMICRO representative directly.

## DISCLAIMER

SG Micro Corp reserves the right to make any change in circuit design, or specifications without prior notice.

## ELECTRICAL PARAMETERS

SYMBOL	PARAMETER
$I_{PP}$	Maximum Reverse Peak Pulse Current
$V_C$	Clamping Voltage @ $I_{PP}$
$V_{RWM}$	Working Peak Reverse Voltage
$I_R$	Maximum Reverse Leakage Current @ $V_{RWM}$
$V_{BR}$	Breakdown Voltage @ $I_T$
$I_T$	Test Current
$V_{TRIG}$	Reverse Trigger Voltage
$V_{HOLD}$	Reverse Holding Voltage

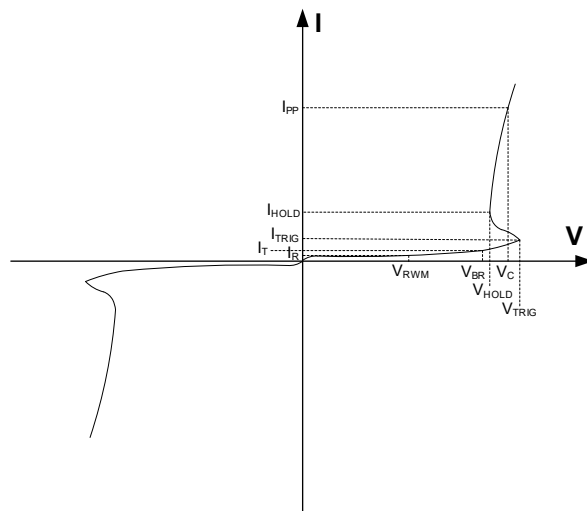

**ELECTRICAL CHARACTERISTICS**(T<sub>A</sub> = +25°C, unless otherwise noted.)

PARAMETER	SYMBOL	CONDITIONS		MIN	TYP	MAX	UNITS
Reverse Working Voltage	V <sub>RWM</sub>	I/O to I/O			3.3	3.6	V
Breakdown Voltage	V <sub>BR</sub>	I <sub>T</sub> = 1mA, I/O to I/O		4.5	5.7	7.3	V
Reverse Leakage Current	I <sub>R</sub>	V <sub>RWM</sub> = 3.3V, I/O to I/O				1	μA
Channel Input Capacitance	C <sub>IN</sub>	V = 0V, f = 1MHz, I/O to I/O			45	60	pF
Surge Clamping Voltage <sup>(1)</sup>	V <sub>C_SURGE</sub>	t <sub>p</sub> = 8/20μs, R <sub>s</sub> = 2Ω	I <sub>PP</sub> = 15A		7.6		V
			I <sub>PP</sub> = 30A		9.1		
TLP Clamping Voltage <sup>(2)</sup>	V <sub>C</sub>	t <sub>p</sub> = 100ns	I <sub>TLP</sub> = 8A		6.56		V
			I <sub>TLP</sub> = 16A		7.45		
Dynamic Resistance <sup>(2)</sup>	R <sub>DYN</sub>	t <sub>p</sub> = 100ns			0.14		Ω

## NOTES:

1. Non-repetitive current pulse 8/20μs exponential decay waveform according to IEC 61000-4-5, 2Ω source impedance.
2. Non-repetitive current pulse, Transmission Line Pulse (TLP) t<sub>p</sub> = 100ns; square pulse.

TYPICAL PERFORMANCE CHARACTERISTICS

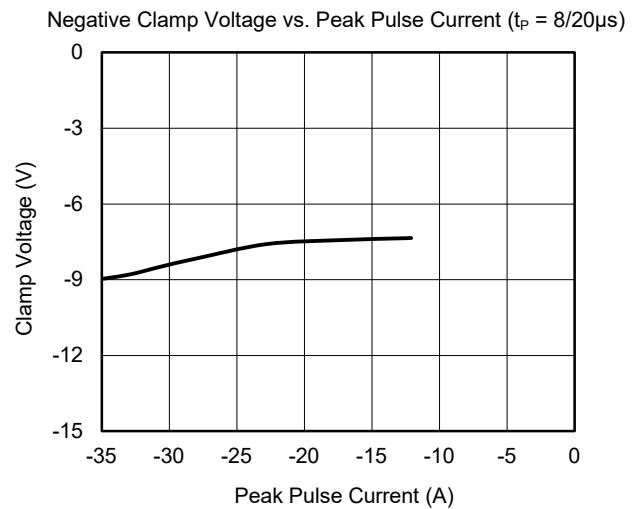
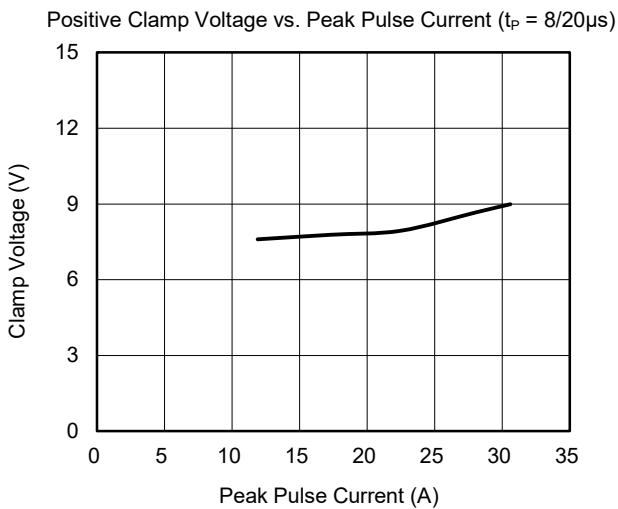
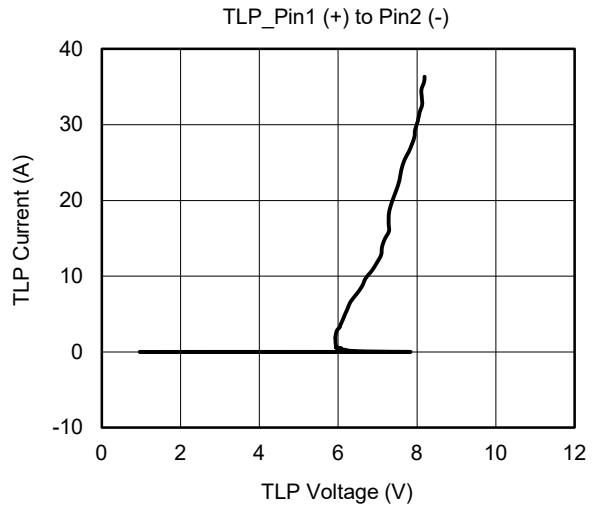
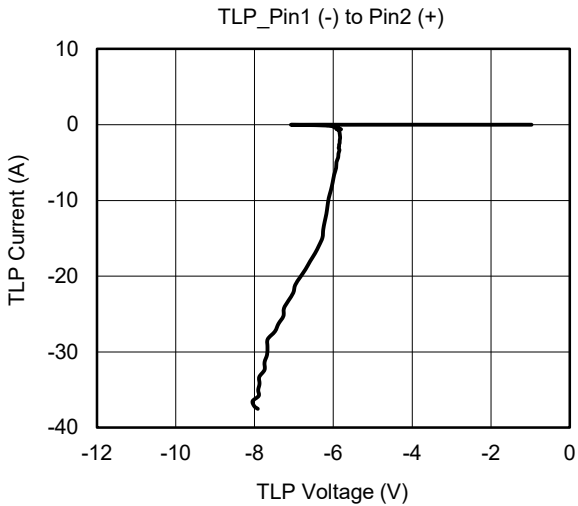
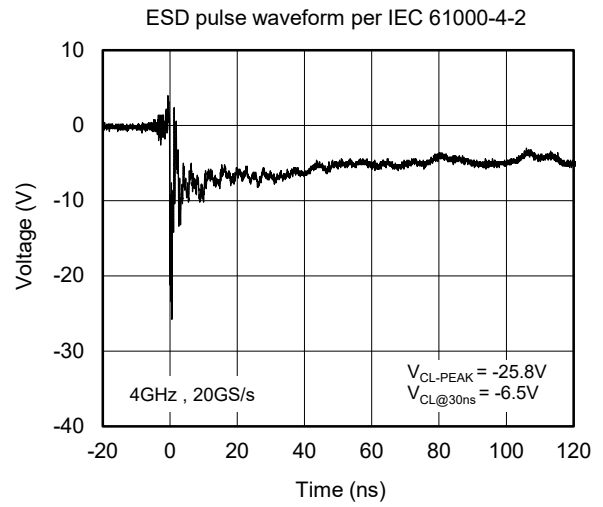
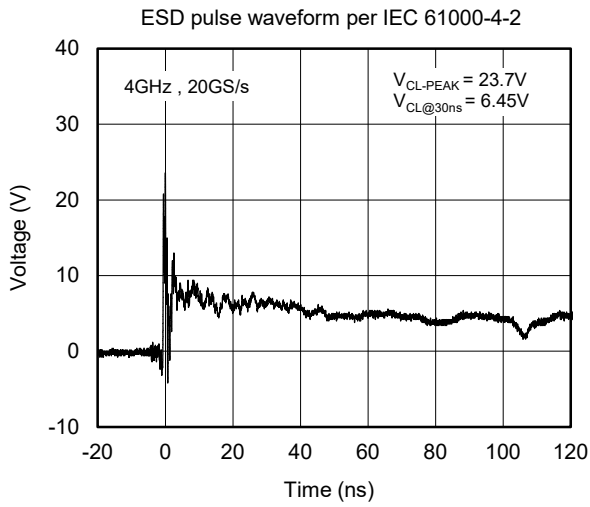

TYPICAL PERFORMANCE CHARACTERISTICS (continued)

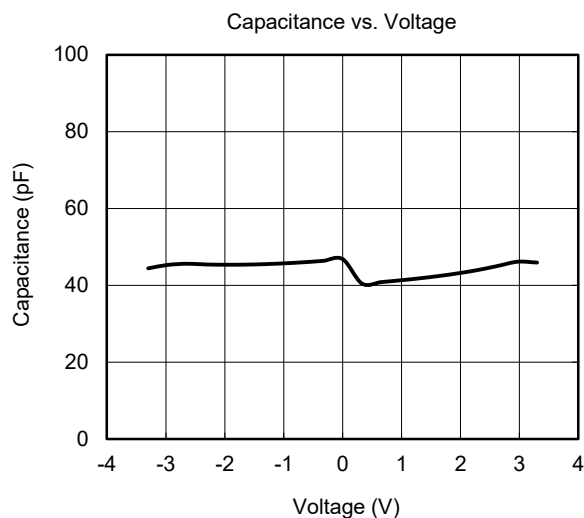
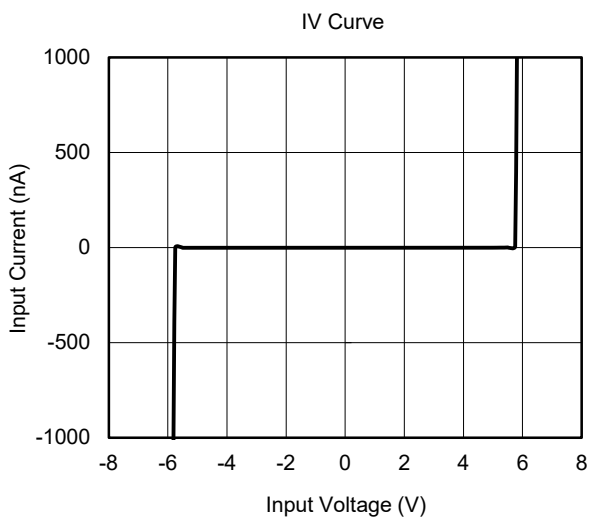

APPLICATION INFORMATION

The TVS is designed to provide a bidirectional line for dissipating ESD events on high-speed signal. The TVS is suitable for lines with positive and negative signal polarity relative to the ground.

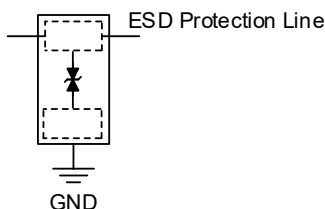

The recommended guidelines are as follows:

1. TVS Placement

Place the TVS as close as possible to the input connector.

2. TVS's Trace Layout

- Avoid running protected traces in parallel with unprotected traces.
- Minimize the path length between the TVS and the protected line.
- Minimize parallel signal path length.
- Route the protected traces as straight as possible.

3. GND Layout

- Avoid using a common ground point shared with the TVS transient return path.
- Minimize the length of the TVS transient return path to ground.
- Use ground vias as close as possible to the TVS transient return to ground.

**REVISION HISTORY**

NOTE: Page numbers for previous revisions may differ from page numbers in the current version.

<b>Changes from Original to REV.A (MARCH 2026)</b>	<b>Page</b>
Changed from product preview to production data.....	All

---

# PACKAGE INFORMATION

## PACKAGE OUTLINE DIMENSIONS

### UTDFN-1×0.6-2AL

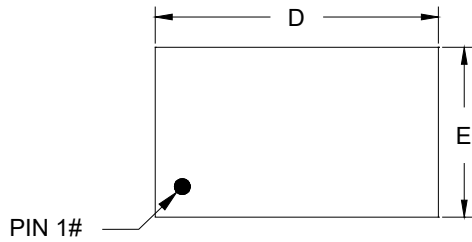

TOP VIEW

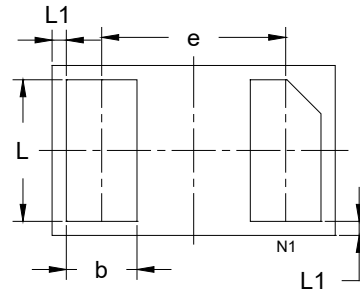

BOTTOM VIEW

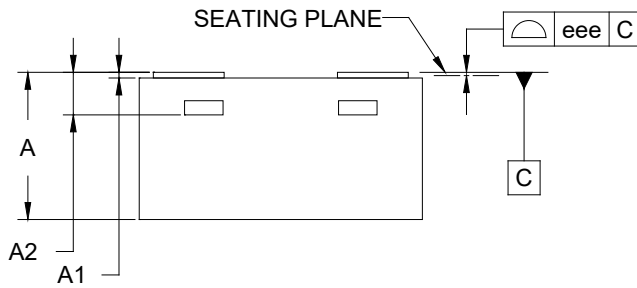

SIDE VIEW

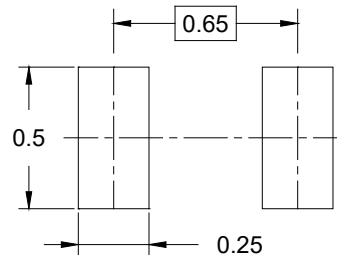

RECOMMENDED LAND PATTERN (Unit: mm)

Symbol	Dimensions In Millimeters		
	MIN	NOM	MAX
A	0.400	-	0.550
A1	0.000	-	0.050
A2	0.150 REF		
b	0.200	-	0.300
D	0.950	-	1.050
E	0.550	-	0.650
e	0.650 BSC		
L	0.450	-	0.550
L1	0.050 REF		
eee	0.050		

NOTE: This drawing is subject to change without notice.

# PACKAGE INFORMATION

## TAPE AND REEL INFORMATION

### REEL DIMENSIONS

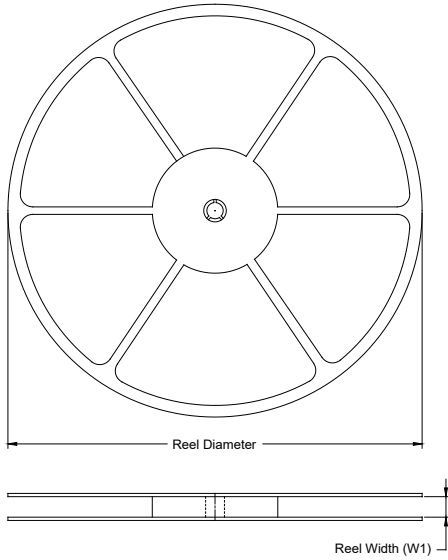

### TAPE DIMENSIONS

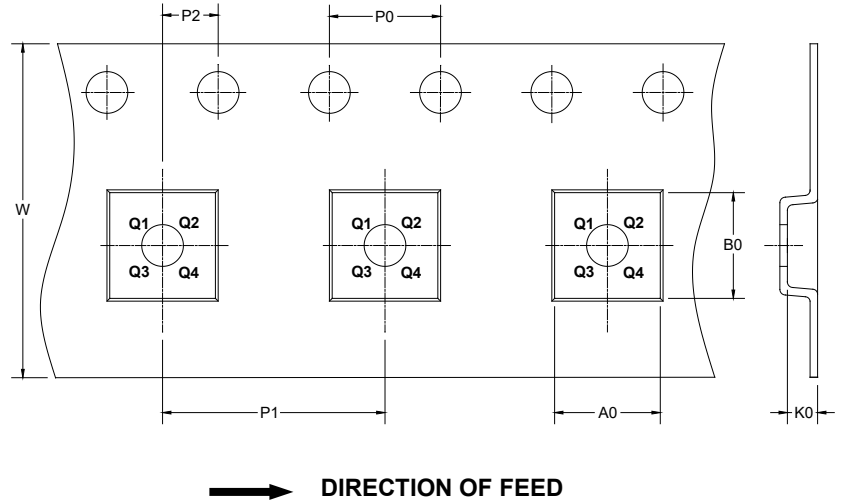

NOTE: The picture is only for reference. Please make the object as the standard.

### KEY PARAMETER LIST OF TAPE AND REEL

Package Type	Reel Diameter	Reel Width W1 (mm)	A0 (mm)	B0 (mm)	K0 (mm)	P0 (mm)	P1 (mm)	P2 (mm)	W (mm)	Pin1 Quadrant
UTDFN-1×0.6-2AL	7"	8.6	0.70	1.12	0.48	4.0	2.0	2.0	8.0	Q1

DD0001

# PACKAGE INFORMATION

## CARTON BOX DIMENSIONS

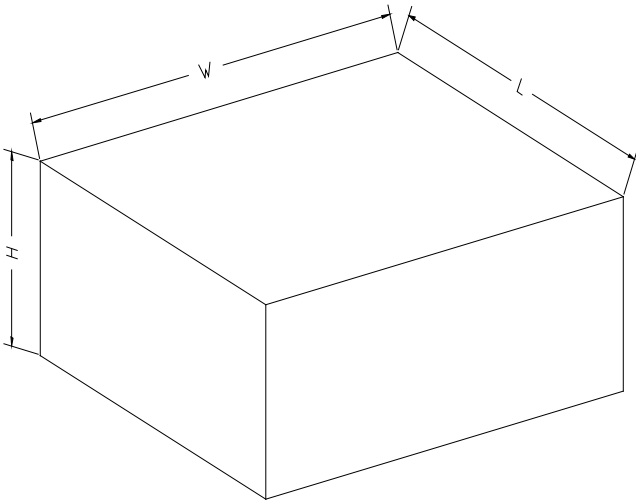

NOTE: The picture is only for reference. Please make the object as the standard.

## KEY PARAMETER LIST OF CARTON BOX

Reel Type	Length (mm)	Width (mm)	Height (mm)	Pizza/Carton
7" (Option)	368	227	224	8
7"	442	410	224	18

D00002