

### GENERAL DESCRIPTION

The SGM13005H1 is a low noise amplifier (LNA) for LTE high band receiver applications. The device features low noise figure and high linearity over a supply voltage range from 1.5V to 3.6V. Low noise figure improves the sensitivity of the SGM13005H1, and high linearity enables the device to provide better immunity to interference signals.

No external DC blocking capacitors are required on the RF paths as long as no external DC voltage is applied, which can save PCB area and cost.

The SGM13005H1 is available in a Green UTDFN-1.1×0.7-6L package.

### APPLICATIONS

Cell Phones  
Tablets  
Other RF Front-End Modules

### FEATURES

- **Operating Frequency Range: 2300MHz to 2700MHz**
- **Low Noise Figure: 1.1dB at 2500MHz**
- **Low Operation Current: 6.1mA**
- **Supply Voltage Range: 1.5V to 3.6V**
- **Input and Output DC Decoupled**
- **Integrated Matching for the Output**
- **Available in Green UTDFN-1.1×0.7-6L Package**

### BLOCK DIAGRAM

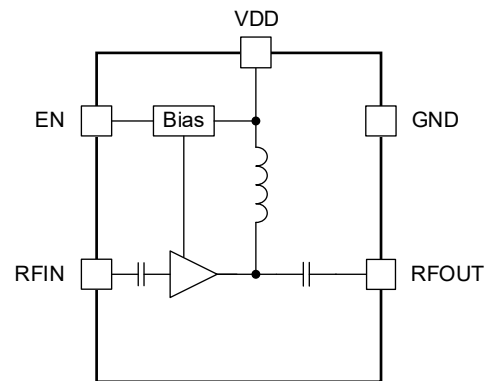

Figure 1. SGM13005H1 Block Diagram

**PACKAGE/ORDERING INFORMATION**

MODEL	PACKAGE DESCRIPTION	SPECIFIED TEMPERATURE RANGE	ORDERING NUMBER	PACKAGE MARKING	PACKING OPTION
SGM13005H1	UTDFN-1.1×0.7-6L	-40°C to +85°C	SGM13005H1YUEC6G/TR	01	Tape and Reel, 10000

**MARKING INFORMATION**

NOTE: Fixed character for 01.

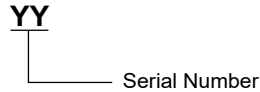

Green (RoHS & HSF): SG Micro Corp defines "Green" to mean Pb-Free (RoHS compatible) and free of halogen substances. If you have additional comments or questions, please contact your SGMICRO representative directly.

**ABSOLUTE MAXIMUM RATINGS**

Supply Voltage, $V_{DD}$ .....	-0.3V to 4.0V
EN to GND.....	-0.3V to 3.6V
Supply Maximum Current, $I_{VDD}$ .....	30mA
RF Input Power, $P_{IN}$ .....	18dBm
Junction Temperature.....	+150°C
Storage Temperature Range.....	-55°C to +150°C
Lead Temperature (Soldering, 10s).....	+260°C
ESD Susceptibility <sup>(1) (2)</sup>	
HBM.....	±1500V
CDM.....	±2000V

NOTES:

1. For human body model (HBM), all pins comply with ANSI/ESDA/JEDEC JS-001 specifications.
2. For charged device model (CDM), all pins comply with ANSI/ESDA/JEDEC JS-002 specifications.

**RECOMMENDED OPERATING CONDITIONS**

Operating Frequency Range, $f_0$ .....	2300MHz to 2700MHz
Operating Temperature Range.....	-40°C to +85°C
Supply Voltage Range, $V_{DD}$ .....	1.5V to 3.6V
Control Voltage High, $V_{CTL\_H}$ .....	1.35V to $V_{DD}$
Control Voltage Low, $V_{CTL\_L}$ .....	0V to 0.45V

**OVERSTRESS CAUTION**

Stresses beyond those listed in Absolute Maximum Ratings may cause permanent damage to the device. Exposure to absolute maximum rating conditions for extended periods may affect reliability. Functional operation of the device at any conditions beyond those indicated in the Recommended Operating Conditions section is not implied.

**ESD SENSITIVITY CAUTION**

This integrated circuit can be damaged if ESD protections are not considered carefully. SGMICRO recommends that all integrated circuits be handled with appropriate precautions. Failure to observe proper handling and installation procedures can cause damage. ESD damage can range from subtle performance degradation to complete device failure. Precision integrated circuits may be more susceptible to damage because even small parametric changes could cause the device not to meet the published specifications.

**DISCLAIMER**

SG Micro Corp reserves the right to make any change in circuit design, or specifications without prior notice.

## PIN CONFIGURATION

(TOP VIEW)

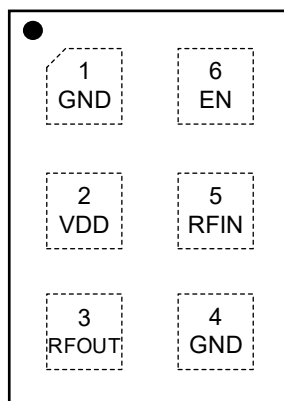

UTDFN-1.1×0.7-6L

## PIN DESCRIPTION

PIN	NAME	FUNCTION
1, 4	GND	Ground.
2	VDD	Power Supply.
3	RFOUT	LNA Output.
5	RFIN	LNA Input from Antenna.
6	EN	Active High Enable Input for the Device.

**ELECTRICAL CHARACTERISTICS**

( $T_A = +25^\circ\text{C}$ ,  $V_{DD} = 1.5\text{V}$  to  $3.6\text{V}$ ,  $f_0 = 2300\text{MHz}$  to  $2700\text{MHz}$ , typical values are at  $V_{DD} = 2.8\text{V}$ , input and output resistance =  $50\Omega$ , unless otherwise noted.)

PARAMETER	SYMBOL	CONDITIONS	MIN	TYP	MAX	UNITS
<b>DC Characteristics</b>						
Supply Voltage	$V_{DD}$		1.5		3.6	V
Supply Current	$I_{VDD}$	EN = High		6.1	7.5	mA
	$I_{SD}$	EN = Low		0.2	1	$\mu\text{A}$
Control Voltage	$V_{CTL\_H}$	High	1.35	1.8	$V_{DD}$	V
	$V_{CTL\_L}$	Low	0	0	0.45	
<b>RF Characteristics</b>						
Power Gain	G	$f_0 = 2300\text{MHz}$	12.8	13.8		dB
		$f_0 = 2500\text{MHz}$	12.7	13.7		
		$f_0 = 2700\text{MHz}$	12.0	12.9		
Input Return Loss	$RL_I$	$f_0 = 2300\text{MHz}$		7.5		dB
		$f_0 = 2500\text{MHz}$		9.0		
		$f_0 = 2700\text{MHz}$		9.9		
Output Return Loss	$RL_O$	$f_0 = 2300\text{MHz}$		10.9		dB
		$f_0 = 2500\text{MHz}$		10.6		
		$f_0 = 2700\text{MHz}$		7.1		
Reverse Isolation	ISO	$f_0 = 2300\text{MHz}$	28.0	28.7		dB
		$f_0 = 2500\text{MHz}$	27.7	28.4		
		$f_0 = 2700\text{MHz}$	28.4	29.1		
Noise Figure	NF	$f_0 = 2300\text{MHz}$		1.1		dB
		$f_0 = 2500\text{MHz}$		1.1		
		$f_0 = 2700\text{MHz}$		1.2		
Input Power 1dB Compression Point	$P_{1dB}$	$f_0 = 2300\text{MHz}$		-5.0		dBm
		$f_0 = 2500\text{MHz}$		-4.3		
		$f_0 = 2700\text{MHz}$		-3.5		
Input In-Band IP3	IIP3_ib	$f_1 = 2300\text{MHz}$ , $f_2 = 2301\text{MHz}$ , $P_1 = P_2 = -25\text{dBm}$		1.2		dBm
		$f_1 = 2500\text{MHz}$ , $f_2 = 2501\text{MHz}$ , $P_1 = P_2 = -25\text{dBm}$		2.1		
		$f_1 = 2700\text{MHz}$ , $f_2 = 2701\text{MHz}$ , $P_1 = P_2 = -25\text{dBm}$		2.9		
Turn-On Time	$t_{ON}$	Time from EN on to 90% of the gain		1.1	1.4	$\mu\text{s}$
Turn-Off Time	$t_{OFF}$	Time from EN off to 10% of the gain		0.1	0.5	$\mu\text{s}$

**ELECTRICAL CHARACTERISTICS (Continued)**

( $T_A = +25^\circ\text{C}$ ,  $V_{DD} = 1.5\text{V}$  to  $3.6\text{V}$ ,  $f_0 = 2300\text{MHz}$  to  $2700\text{MHz}$ , typical values are at  $V_{DD} = 1.8\text{V}$ , input and output resistance =  $50\Omega$ , unless otherwise noted.)

PARAMETER	SYMBOL	CONDITIONS	MIN	TYP	MAX	UNITS
<b>DC Characteristics</b>						
Supply Voltage	$V_{DD}$		1.5		3.6	V
Supply Current	$I_{VDD}$	EN = High		6.4	7.8	mA
	$I_{SD}$	EN = Low		0.2	1	$\mu\text{A}$
Control Voltage	$V_{CTL\_H}$	High	1.35	1.8	$V_{DD}$	V
	$V_{CTL\_L}$	Low	0	0	0.45	
<b>RF Characteristics</b>						
Power Gain	G	$f_0 = 2300\text{MHz}$	12.9	13.9		dB
		$f_0 = 2500\text{MHz}$	12.8	13.6		
		$f_0 = 2700\text{MHz}$	11.9	12.8		
Input Return Loss	$RL_I$	$f_0 = 2300\text{MHz}$		7.6		dB
		$f_0 = 2500\text{MHz}$		9.2		
		$f_0 = 2700\text{MHz}$		9.9		
Output Return Loss	$RL_O$	$f_0 = 2300\text{MHz}$		11.8		dB
		$f_0 = 2500\text{MHz}$		10.4		
		$f_0 = 2700\text{MHz}$		6.8		
Reverse Isolation	ISO	$f_0 = 2300\text{MHz}$	28.0	28.7		dB
		$f_0 = 2500\text{MHz}$	27.7	28.4		
		$f_0 = 2700\text{MHz}$	28.2	28.9		
Noise Figure	NF	$f_0 = 2300\text{MHz}$		1.1		dB
		$f_0 = 2500\text{MHz}$		1.1		
		$f_0 = 2700\text{MHz}$		1.1		
Input Power 1dB Compression Point	$P_{1dB}$	$f_0 = 2300\text{MHz}$		-7.0		dBm
		$f_0 = 2500\text{MHz}$		-6.5		
		$f_0 = 2700\text{MHz}$		-5.6		
Input In-Band IP3	IIP3_ib	$f_1 = 2300\text{MHz}$ , $f_2 = 2301\text{MHz}$ , $P_1 = P_2 = -25\text{dBm}$		1.0		dBm
		$f_1 = 2500\text{MHz}$ , $f_2 = 2501\text{MHz}$ , $P_1 = P_2 = -25\text{dBm}$		1.8		
		$f_1 = 2700\text{MHz}$ , $f_2 = 2701\text{MHz}$ , $P_1 = P_2 = -25\text{dBm}$		2.6		
Turn-On Time	$t_{ON}$	Time from EN on to 90% of the gain		1.3	1.5	$\mu\text{s}$
Turn-Off Time	$t_{OFF}$	Time from EN off to 10% of the gain		0.1	0.5	$\mu\text{s}$

TYPICAL APPLICATION CIRCUIT

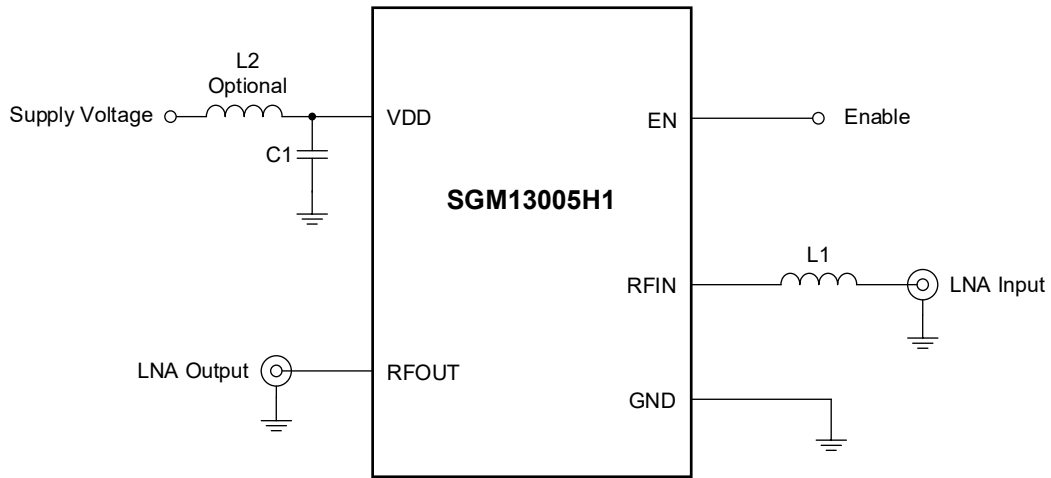

Figure 2. SGM13005H1 Typical Application Circuit

Table 1. Inductor Selection Table

Part	Typical (nH)	Q (min)	Frequency (MHz)	MFR	Size
LQW15A	4.7	25	250	Murata	0402

Table 2. Capacitor Selection Table

Part	Typical (pF)	Voltage (V)	MFR	Size
GRM155	1000	50	Murata	0402

EVALUATION BOARD LAYOUT

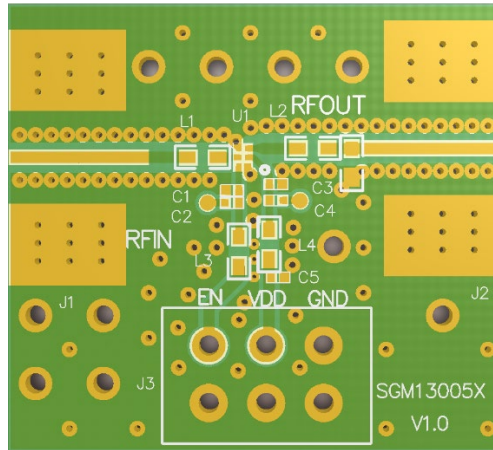

Figure 3. Evaluation Board Layout

**REVISION HISTORY**

NOTE: Page numbers for previous revisions may differ from page numbers in the current version.

<b>SEPTEMBER 2025 – REV.A.1 to REV.A.2</b>	<b>Page</b>
Updated Package Outline Dimensions.....	8

---

<b>APRIL 2024 – REV.A to REV.A.1</b>	<b>Page</b>
Updated Electrical Characteristics section.....	4, 5

---

<b>Changes from Original (DECEMBER 2022) to REV.A</b>	<b>Page</b>
Changed from product preview to production data.....	All

---

PACKAGE OUTLINE DIMENSIONS

UTDFN-1.1×0.7-6L

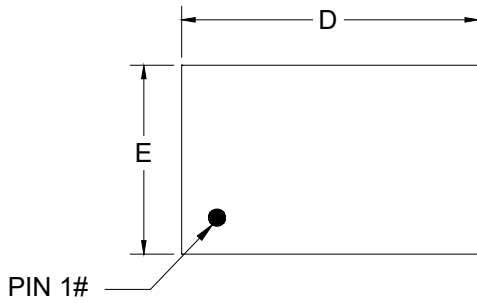

TOP VIEW

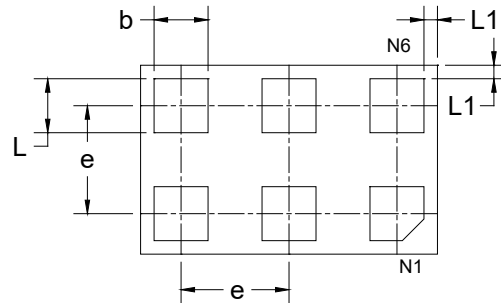

BOTTOM VIEW

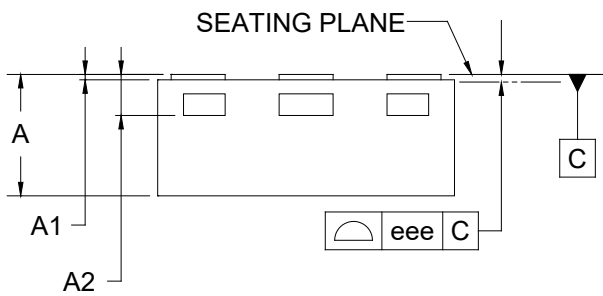

SIDE VIEW

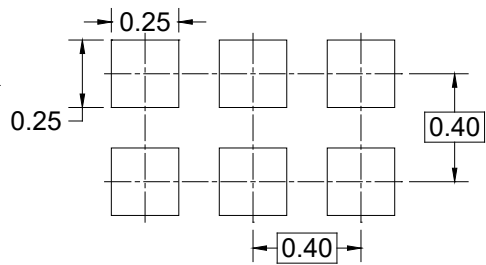

RECOMMENDED LAND PATTERN (Unit: mm)

Symbol	Dimensions In Millimeters		
	MIN	NOM	MAX
A	0.400	-	0.500
A1	0.000	-	0.050
A2	0.152 REF		
b	0.150	-	0.250
D	1.050	-	1.150
E	0.650	-	0.750
e	0.400 BSC		
L	0.150	-	0.250
L1	0.000	-	0.100
eee	0.080		

NOTE: This drawing is subject to change without notice.

# PACKAGE INFORMATION

## TAPE AND REEL INFORMATION

### REEL DIMENSIONS

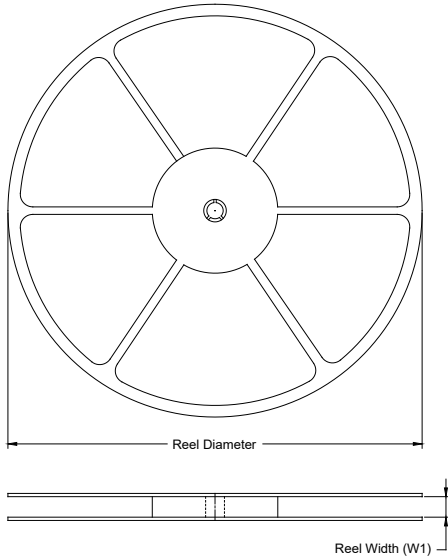

### TAPE DIMENSIONS

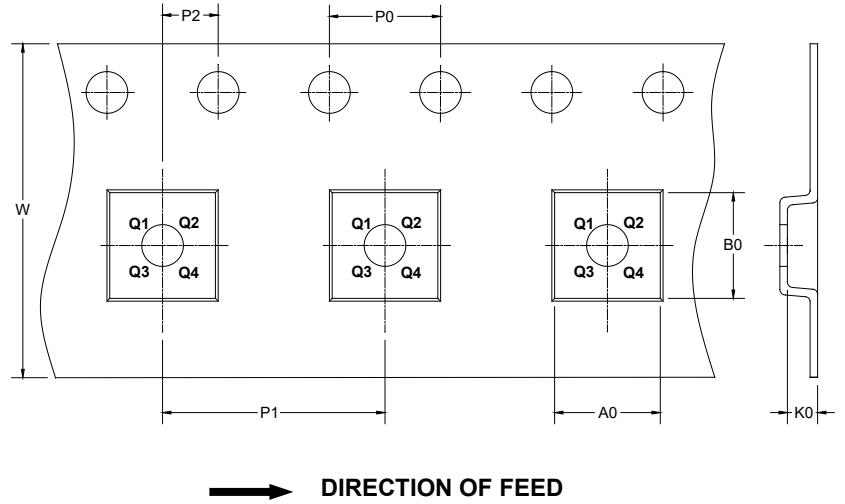

NOTE: The picture is only for reference. Please make the object as the standard.

### KEY PARAMETER LIST OF TAPE AND REEL

Package Type	Reel Diameter	Reel Width W1 (mm)	A0 (mm)	B0 (mm)	K0 (mm)	P0 (mm)	P1 (mm)	P2 (mm)	W (mm)	Pin1 Quadrant
UTDFN-1.1×0.7-6L	7"	9.5	0.80	1.20	0.55	4.0	2.0	2.0	8.0	Q1

DD0001

# PACKAGE INFORMATION

## CARTON BOX DIMENSIONS

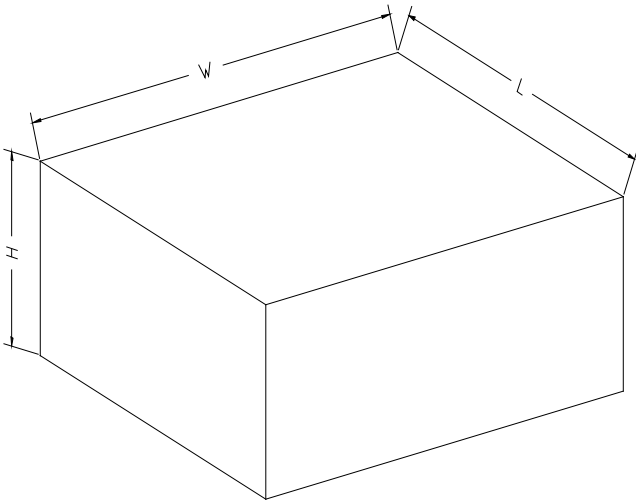

NOTE: The picture is only for reference. Please make the object as the standard.

## KEY PARAMETER LIST OF CARTON BOX

Reel Type	Length (mm)	Width (mm)	Height (mm)	Pizza/Carton
7" (Option)	368	227	224	8
7"	442	410	224	18

D00002