



SGM2232AxQ

Automotive 150mA, High Voltage, Ultra-Low I_Q, High PSRR, Low Dropout Regulator

GENERAL DESCRIPTION

The SGM2232AxQ is a high voltage, ultra-low quiescent current, high PSRR and low dropout voltage linear regulator. It is capable of supplying 150mA output current with typical dropout voltage of 570mV. The operating input voltage range is from 4.5V to 40V and output voltage range is from 2.5V to 5V.

Other features include under-voltage lockout, current limit and thermal shutdown protection. The SGM2232AxQ is suitable for various automotive applications.

This device is AEC-Q100 qualified (Automotive Electronics Council (AEC) standard Q100 Grade 1) and it is suitable for automotive applications.

The SGM2232AxQ is available in Green SOT-223-3 and SOT-23-5 packages. It operates over an operating temperature range of -40°C to +125°C.

APPLICATIONS

Automotive Applications
Industrial Equipment
Medical Equipment
Telecom Equipment
Wireless Equipment

FEATURES

- **AEC-Q100 Qualified for Automotive Applications**
Device Temperature Grade 1
 $T_A = -40^{\circ}\text{C}$ to $+125^{\circ}\text{C}$
- **Operating Input Voltage Range: 4.5V to 40V**
- **Fixed Output from 2.5V to 5V**
- **150mA Output Current**
- **Output Voltage Accuracy:**
 $\pm 3\%$ at $T_J = -40^{\circ}\text{C}$ to $+125^{\circ}\text{C}$
- **Low Quiescent Current: 16 μA (TYP)**
- **Low Dropout Voltage:**
570mV (TYP) at 150mA, $V_{\text{OUT(NOM)}} = 5\text{V}$
- **High PSRR:**
 - ◆ **84dB (TYP) at 1kHz**
 - ◆ **56dB (TYP) at 100kHz**
 - ◆ **63dB (TYP) at 1MHz**
- **Current Limiting and Thermal Protection**
- **Under-Voltage Lockout (UVLO)**
- **Stable with Low ESR Ceramic Capacitors**
- **-40°C to +125°C Operating Temperature Range**
- **Available in Green SOT-223-3 and SOT-23-5 Packages**

TYPICAL APPLICATION

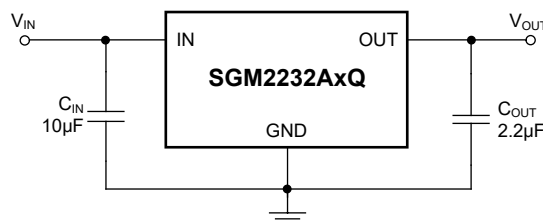

Figure 1. Typical Application Circuit

Automotive 150mA, High Voltage, Ultra-Low I_Q, SGM2232AxQ High PSRR, Low Dropout Regulator

PACKAGE/ORDERING INFORMATION

MODEL	PACKAGE DESCRIPTION	SPECIFIED TEMPERATURE RANGE	ORDERING NUMBER	PACKAGE TOP MARKING	PACKING OPTION
SGM2232A-2.5Q	SOT-223-3	-40°C to +125°C (T _A)	SGM2232A-2.5QKC3G/TR	2V8 XXXXY	Tape and Reel, 2500
SGM2232A-3.3Q	SOT-223-3	-40°C to +125°C (T _A)	SGM2232A-3.3QKC3G/TR	2V9 XXXXY	Tape and Reel, 2500
SGM2232A-5.0Q	SOT-223-3	-40°C to +125°C (T _A)	SGM2232A-5.0QKC3G/TR	2VA XXXXY	Tape and Reel, 2500
SGM2232A-2.5Q	SOT-23-5	-40°C to +125°C (T _A)	SGM2232A-2.5QN5G/TR	2VB XXXXY	Tape and Reel, 3000
SGM2232A-3.3Q	SOT-23-5	-40°C to +125°C (T _A)	SGM2232A-3.3QN5G/TR	2VC XXXXY	Tape and Reel, 3000
SGM2232A-5.0Q	SOT-23-5	-40°C to +125°C (T _A)	SGM2232A-5.0QN5G/TR	2VD XXXXY	Tape and Reel, 3000

MARKING INFORMATION

NOTE: XXXYY = Date Code, Trace Code and Lot Number.

SOT-223-3/SOT-23-5

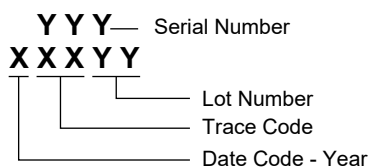

Green (RoHS & HSF): SG Micro Corp defines "Green" to mean Pb-Free (RoHS compatible) and free of halogen substances. If you have additional comments or questions, please contact your SGMICRO representative directly.

Automotive 150mA, High Voltage, Ultra-Low I_Q, High PSRR, Low Dropout Regulator

SGM2232AxQ

ABSOLUTE MAXIMUM RATINGS

IN to GND	-0.3V to 45V
OUT to GND	-0.3V to 7V
Package Thermal Resistance	
SOT-223-3, θ_{JA}	60.1°C/W
SOT-223-3, θ_{JB}	10.6°C/W
SOT-223-3, θ_{JC}	32.6°C/W
SOT-23-5, θ_{JA}	164.1°C/W
SOT-23-5, θ_{JB}	28.6°C/W
SOT-23-5, θ_{JC}	51.8°C/W
Junction Temperature.....	+150°C
Storage Temperature Range	-65°C to +150°C
Lead Temperature (Soldering, 10s).....	+260°C
ESD Susceptibility ⁽¹⁾⁽²⁾	
HBM.....	±3000V
CDM	±1000V

NOTES:

1. For human body model (HBM), all pins comply with AEC-Q100-002 specification.
2. For charged device model (CDM), all pins comply with AEC-Q100-011 specification.

RECOMMENDED OPERATING CONDITIONS

Input Voltage Range	4.5V to 40V
Input Effective Capacitance, C _{IN}	2.2µF (MIN)
Output Effective Capacitance, C _{OUT}	1.5µF to 100µF
Operating Ambient Temperature Range	-40°C to +125°C
Operating Junction Temperature Range	-40°C to +150°C

OVERSTRESS CAUTION

Stresses beyond those listed in Absolute Maximum Ratings may cause permanent damage to the device. Exposure to absolute maximum rating conditions for extended periods may affect reliability. Functional operation of the device at any conditions beyond those indicated in the Recommended Operating Conditions section is not implied.

ESD SENSITIVITY CAUTION

This integrated circuit can be damaged if ESD protections are not considered carefully. SGMICRO recommends that all integrated circuits be handled with appropriate precautions. Failure to observe proper handling and installation procedures can cause damage. ESD damage can range from subtle performance degradation to complete device failure. Precision integrated circuits may be more susceptible to damage because even small parametric changes could cause the device not to meet the published specifications.

DISCLAIMER

SG Micro Corp reserves the right to make any change in circuit design, or specifications without prior notice.

PIN CONFIGURATIONS

SGM2232AxQ (TOP VIEW)

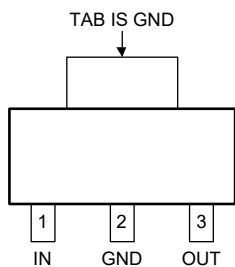

SOT-223-3

SGM2232AxQ (TOP VIEW)

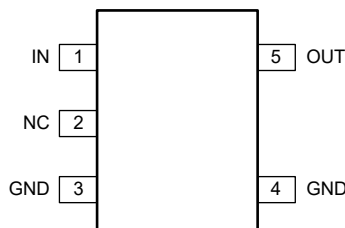

SOT-23-5

PIN DESCRIPTION

PIN		NAME	FUNCTION
SOT-223-3	SOT-23-5		
1	1	IN	Input Supply Voltage Pin. It is recommended to use a 10μF or larger ceramic capacitor from IN pin to ground. This ceramic capacitor should be placed as close as possible to the IN pin.
2, TAB	3, 4	GND	Ground.
3	5	OUT	Regulator Output Pin. It is recommended to use a ceramic capacitor with effective capacitance in the range of 1.5μF to 100μF. This ceramic capacitor should be placed as close as possible to the OUT pin.
—	2	NC	No Connection.

SGM2232AxQ Automotive 150mA, High Voltage, Ultra-Low I_Q , High PSRR, Low Dropout Regulator

FUNCTIONAL BLOCK DIAGRAM

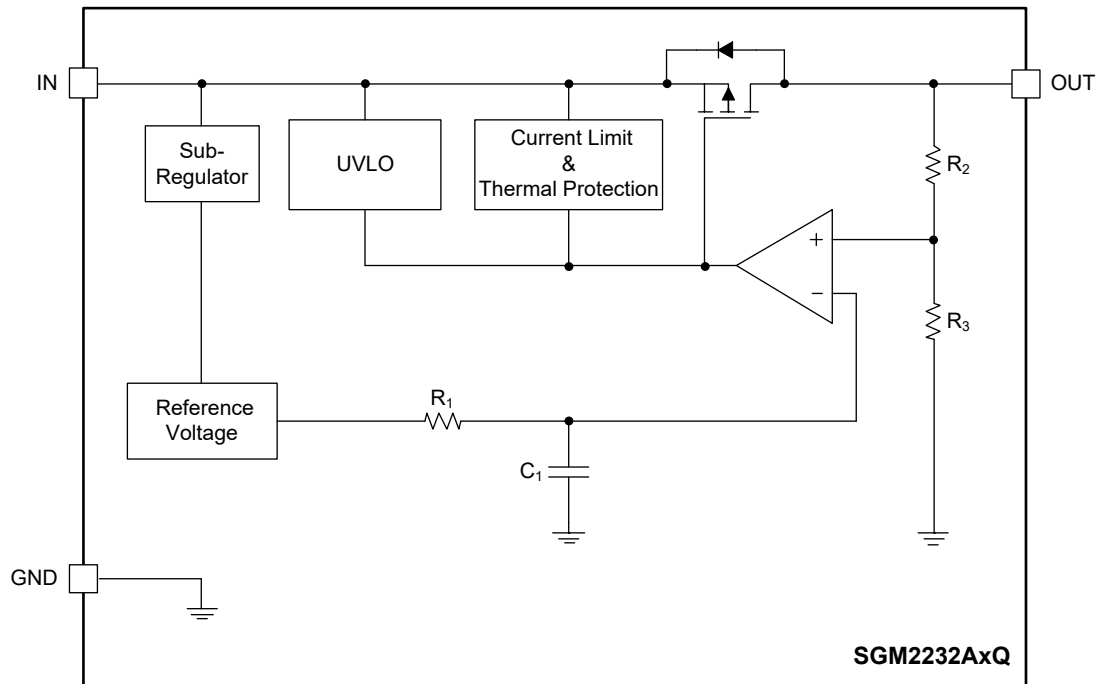

Figure 2. Block Diagram

Automotive 150mA, High Voltage, Ultra-Low I_Q, High PSRR, Low Dropout Regulator

SGM2232AxQ

ELECTRICAL CHARACTERISTICS

(V_{IN} = V_{OUT(NOM)} + 1.5V, C_{IN} = 10μF, C_{OUT} = 2.2μF, T_J = -40°C to +150°C, typical values are at T_J = +25°C, unless otherwise noted.)

PARAMETER	SYMBOL	CONDITIONS	MIN	TYP	MAX	UNITS	
Input Voltage Range	V _{IN}	V _{OUT(NOM)} = 2.5V	4.5		40	V	
		V _{OUT(NOM)} = 3.3V	4.5		40		
		V _{OUT(NOM)} = 5V	5.5		40		
Output Voltage Accuracy	V _{OUT}	V _{IN} = (V _{OUT(NOM)} + 1.5V) to 40V, I _{OUT} = 1mA to 150mA	-3		+3	%	
Under-Voltage Lockout Thresholds	V _{UVLO}	V _{IN} rising	3.2		4.4	V	
		V _{IN} falling	2.8		3.9		
Line Regulation	ΔV _{LNR}	V _{IN} = (V _{OUT(NOM)} + 1.5V) to 40V, I _{OUT} = 1mA		0.5	15	mV	
Load Regulation	ΔV _{LDR}	I _{OUT} = 1mA to 150mA		14	20	mV	
Dropout Voltage ⁽¹⁾	V _{DROP}	V _{OUT(NOM)} = 5V	I _{OUT} = 50mA		180	400	mV
			I _{OUT} = 100mA		365	800	
			I _{OUT} = 150mA		570	1200	
Output Current Limit	I _{LIMIT}	V _{OUT} = 90% × V _{OUT(NOM)}	200	345		mA	
Short-Circuit Current Limit	I _{SHORT}	V _{OUT} = 0V		285		mA	
Quiescent Current	I _Q	I _{OUT} = 0mA		16	35	μA	
Start-Up Time	t _{STR}	From V _{IN} rising from 0V to V _{IN} to V _{OUT} = 90% × V _{OUT(NOM)}		200	400	μs	
Power Supply Ripple Rejection	PSRR	ΔV _{RIPPLE} = 0.5V _{P-P} , V _{IN} = 14V, I _{OUT} = 10mA	f = 100Hz		95		dB
			f = 1kHz		84		
			f = 100kHz		56		
			f = 1MHz		63		
Thermal Shutdown Temperature	T _{SHDN}	T _J rising		180		°C	
Thermal Shutdown Hysteresis	ΔT _{SHDN}	Hysteresis		30		°C	

NOTE:

- The dropout voltage is defined as the difference between V_{IN} and V_{OUT} when V_{OUT} falls to 95% × V_{OUT(NOM)}.

SGM2232AxQ Automotive 150mA, High Voltage, Ultra-Low I_Q, High PSRR, Low Dropout Regulator

TYPICAL PERFORMANCE CHARACTERISTICS

T_J = +25°C, V_{IN} = 14V, I_{OUT} = 10mA, C_{IN} = 10μF, C_{OUT} = 2.2μF, unless otherwise noted.

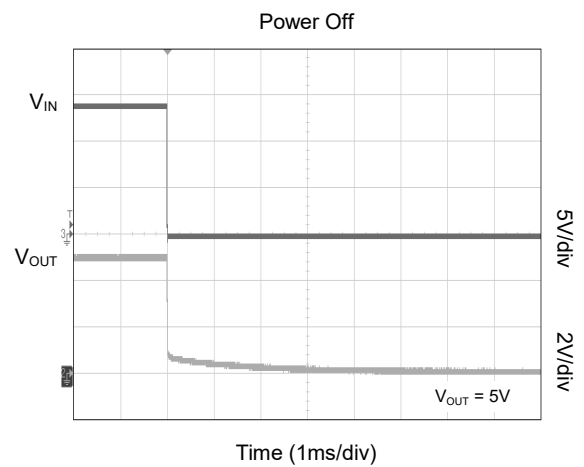
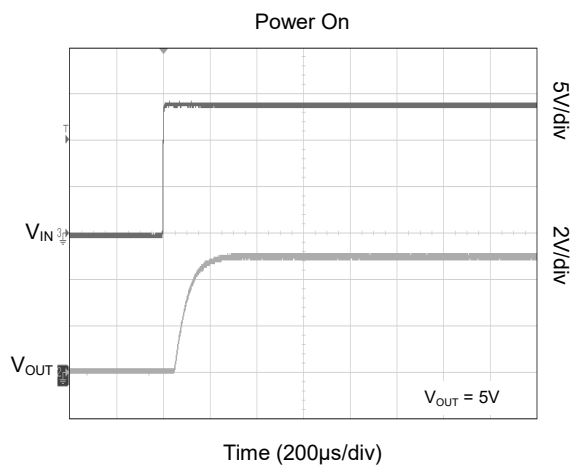
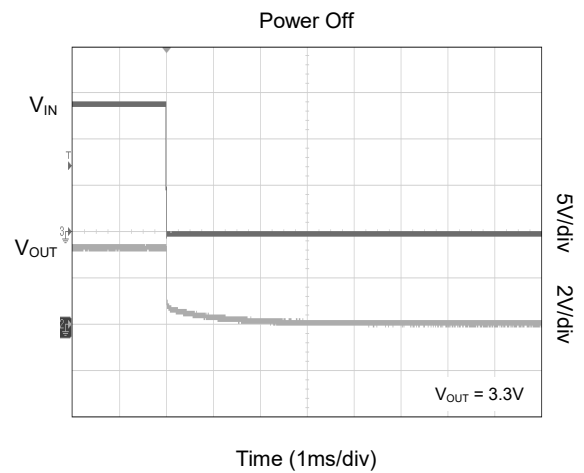
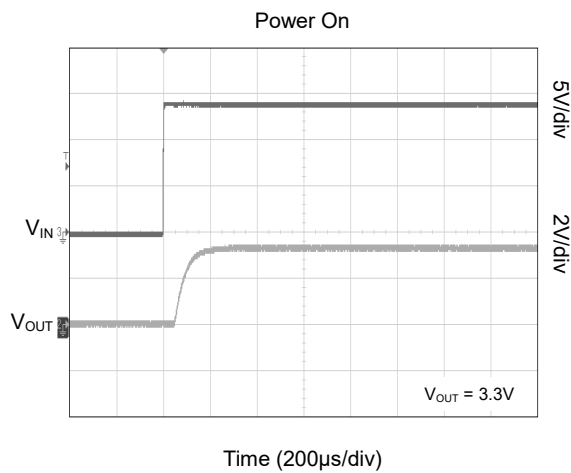
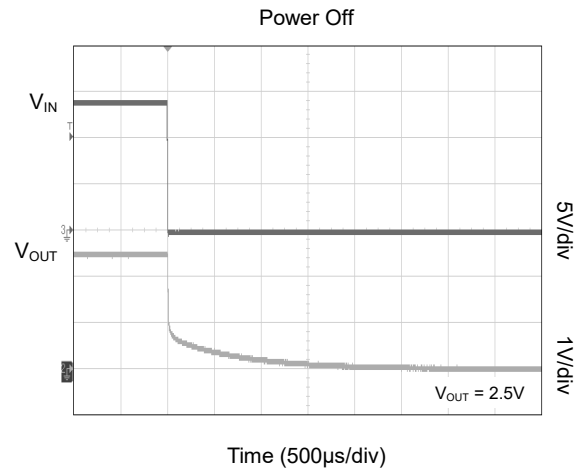
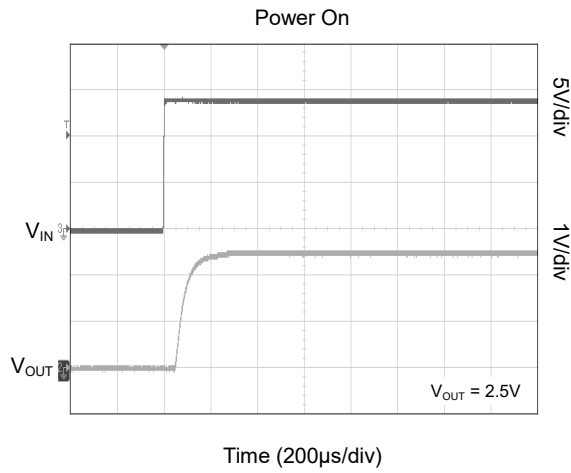

Automotive 150mA, High Voltage, Ultra-Low I_Q, High PSRR, Low Dropout Regulator

SGM2232AxQ

TYPICAL PERFORMANCE CHARACTERISTICS (continued)

T_J = +25°C, V_{IN} = 14V, I_{OUT} = 10mA, C_{IN} = 10μF, C_{OUT} = 2.2μF, unless otherwise noted.

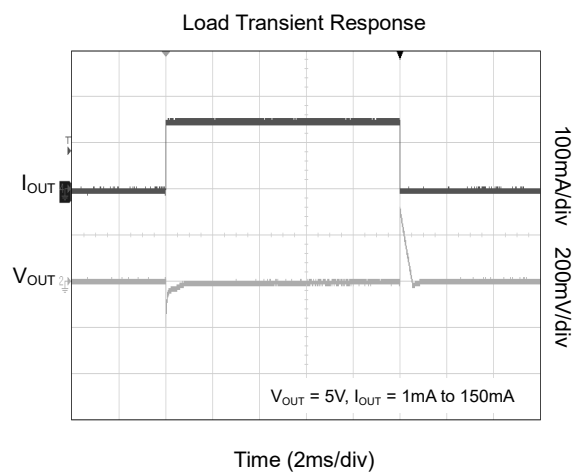
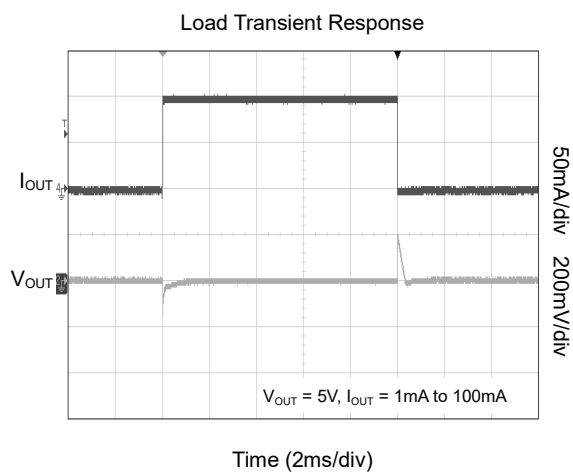
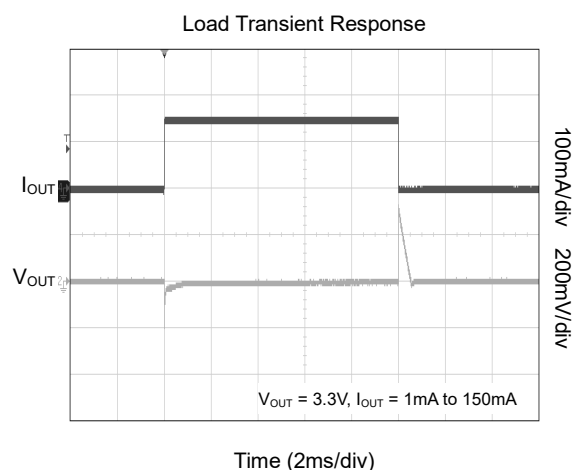
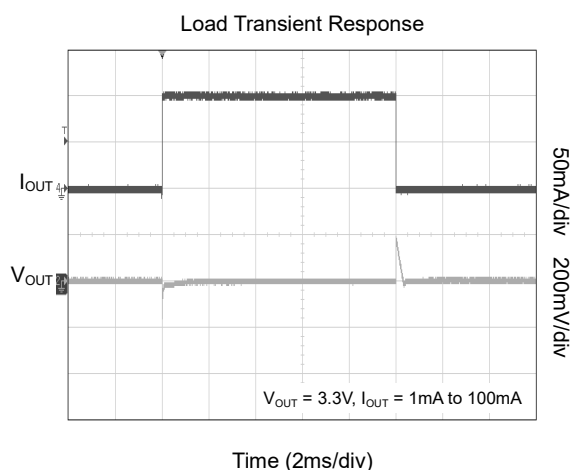
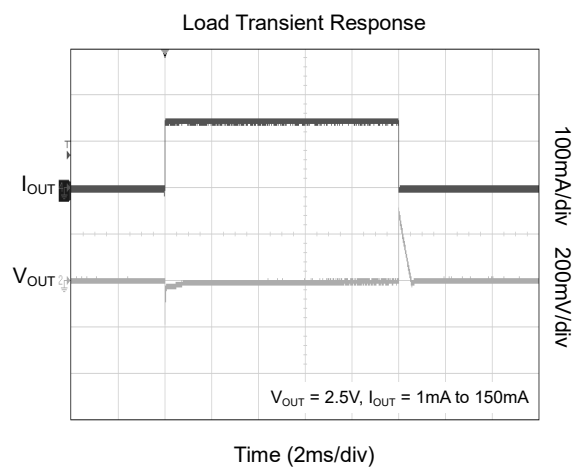
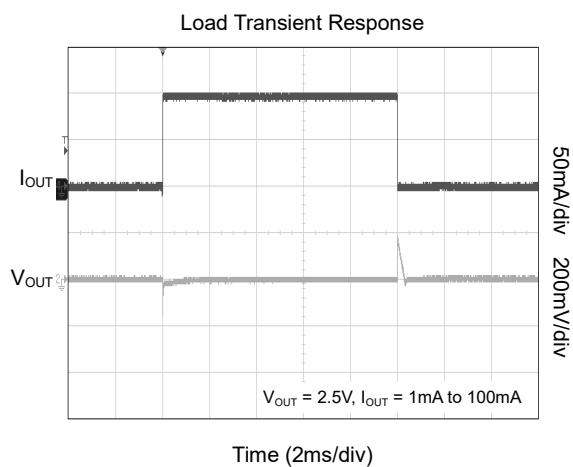

Automotive 150mA, High Voltage, Ultra-Low I_Q, High PSRR, Low Dropout Regulator

SGM2232AxQ

TYPICAL PERFORMANCE CHARACTERISTICS (continued)

$T_J = +25^\circ\text{C}$, $V_{IN} = 14\text{V}$, $I_{OUT} = 10\text{mA}$, $C_{IN} = 10\mu\text{F}$, $C_{OUT} = 2.2\mu\text{F}$, unless otherwise noted.

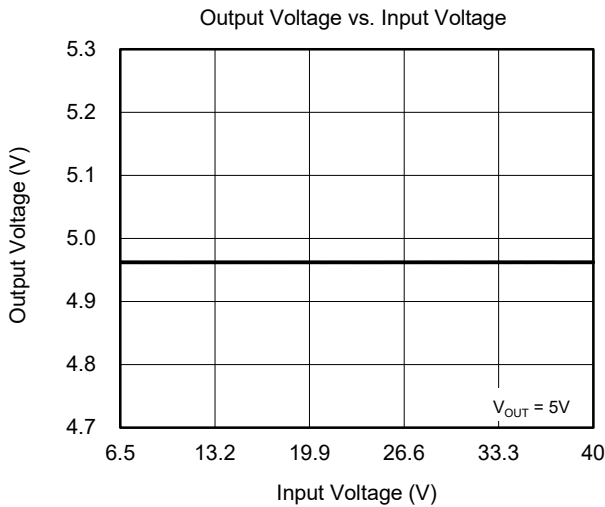
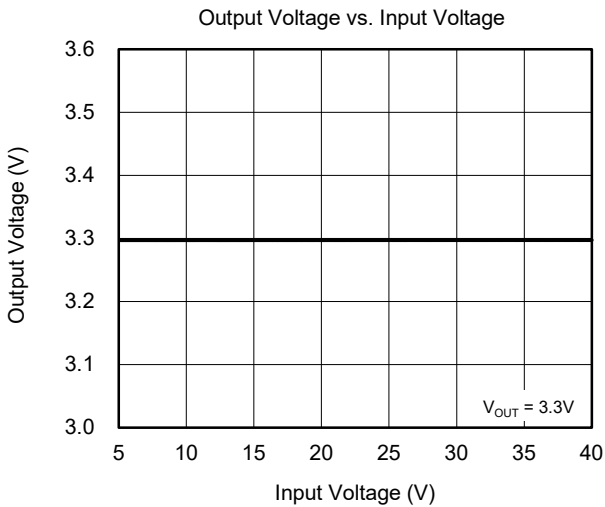
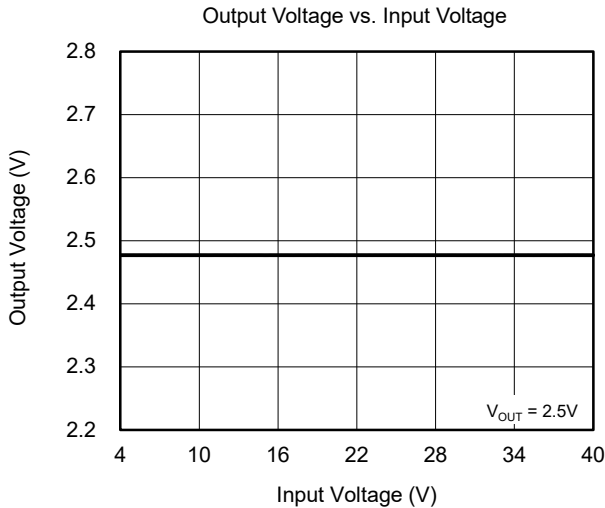
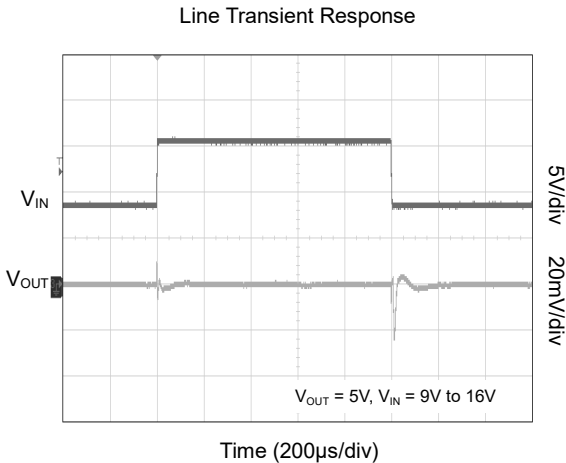
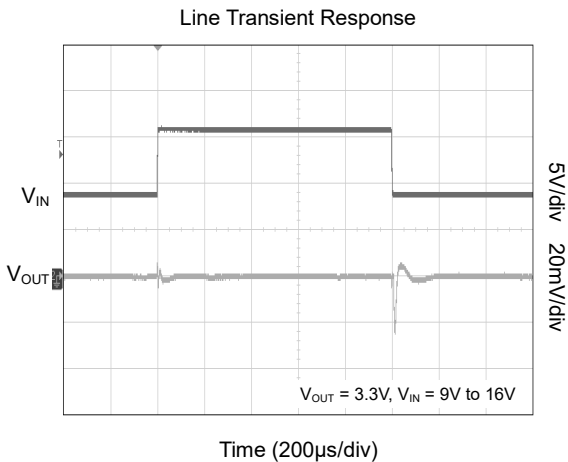
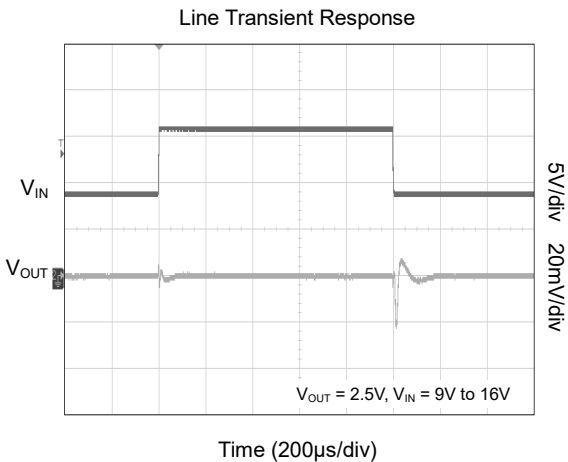

Automotive 150mA, High Voltage, Ultra-Low I_Q, High PSRR, Low Dropout Regulator

SGM2232AxQ

TYPICAL PERFORMANCE CHARACTERISTICS (continued)

T_J = +25°C, V_{IN} = 14V, I_{OUT} = 10mA, C_{IN} = 10μF, C_{OUT} = 2.2μF, unless otherwise noted.

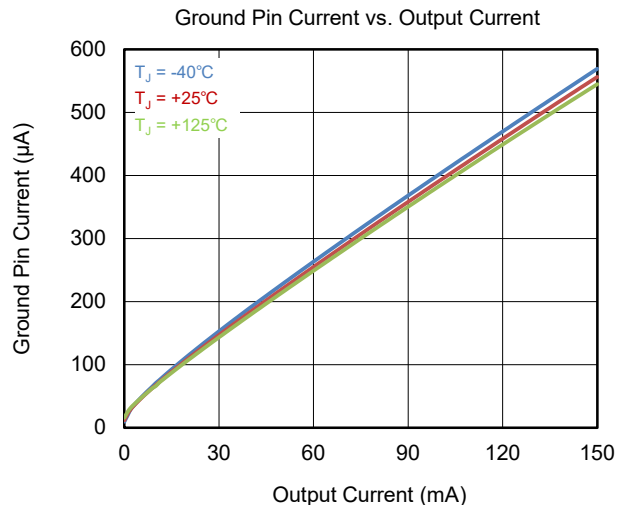
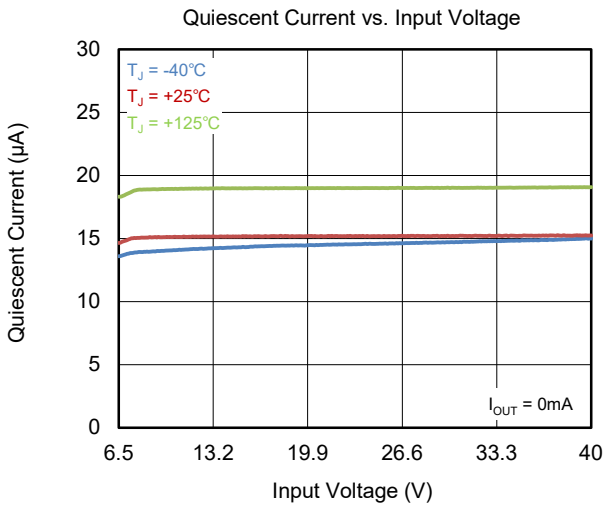
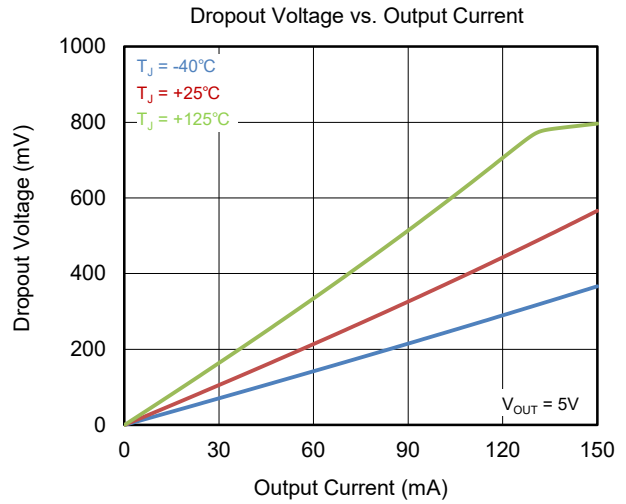
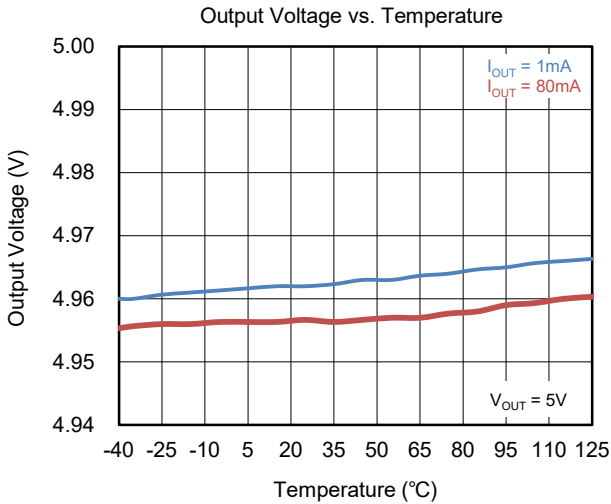
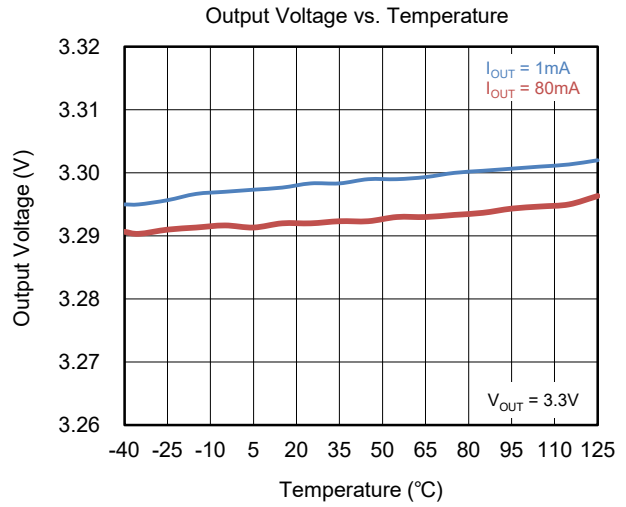
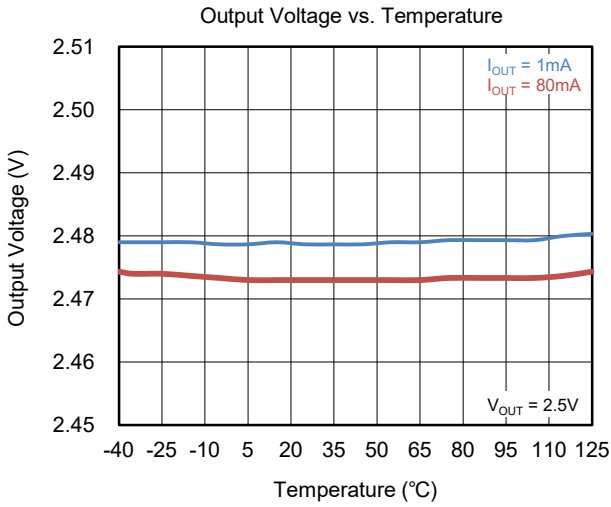

SGM2232AxQ Automotive 150mA, High Voltage, Ultra-Low I_Q, High PSRR, Low Dropout Regulator

TYPICAL PERFORMANCE CHARACTERISTICS (continued)

T_J = +25°C, V_{IN} = 14V, I_{OUT} = 10mA, C_{IN} = 10μF, C_{OUT} = 2.2μF, unless otherwise noted.

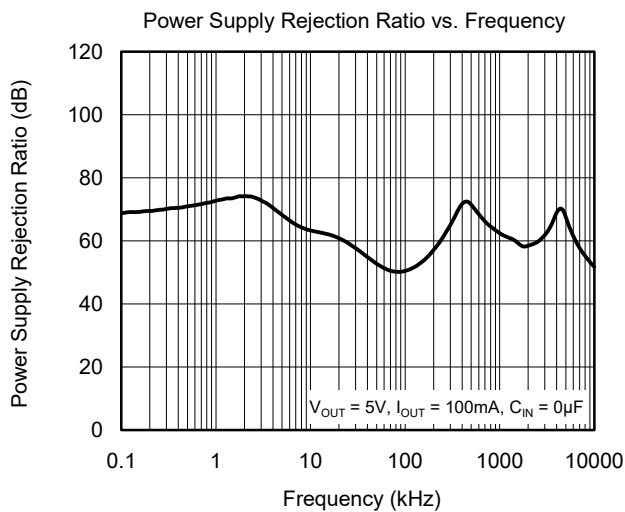
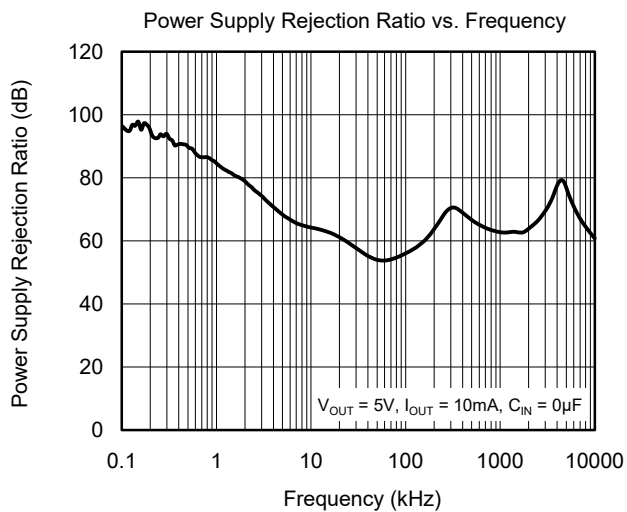

APPLICATION INFORMATION

The SGM2232AxQ is a high voltage, ultra-low quiescent current, high PSRR and low dropout LDO and provides 150mA output current. These features make the device useful in a variety of applications. The SGM2232AxQ provides protection functions for output overload and overheating.

Input Capacitor Selection (C_{IN})

The input decoupling capacitor should be placed as close as possible to the IN pin to ensure the device stability. 10µF or larger X7R or X5R ceramic capacitor is selected to get good dynamic performance.

When V_{IN} is required to provide large current instantaneously, a large effective input capacitor is required. Multiple input capacitors can limit the input tracking inductance. Adding more input capacitors is available to restrict the ringing and to keep it below the device absolute maximum ratings. For C_{OUT} with larger capacitance, it is recommended to choose the larger capacitance C_{IN}.

Output Capacitor Selection (C_{OUT})

One or more output capacitors are required to maintain the stability of the LDO, and the output capacitors should be placed as close as possible to the OUT pin. In addition, in order to obtain the best transient performance, it is recommended to use X7R and X5R ceramic capacitors as output capacitors. Ceramic capacitors have low equivalent series resistance (ESR), excellent temperature and DC bias characteristics. However, it cannot be ignored that the effective capacitance of ceramic capacitors is affected by temperature, DC bias and package size.

For example, Figure 3 shows the capacitance and DC bias and temperature characteristics of 0805, 10V, 10µF±10%, X7R capacitor. Therefore, it is necessary to evaluate whether the effective capacitance of the output capacitor can meet the stability requirements of the LDO in practical applications. In general, a capacitor in higher voltage rating and a larger package exhibits better stability, and the effective capacitance can be obtained from the manufacturer datasheet.

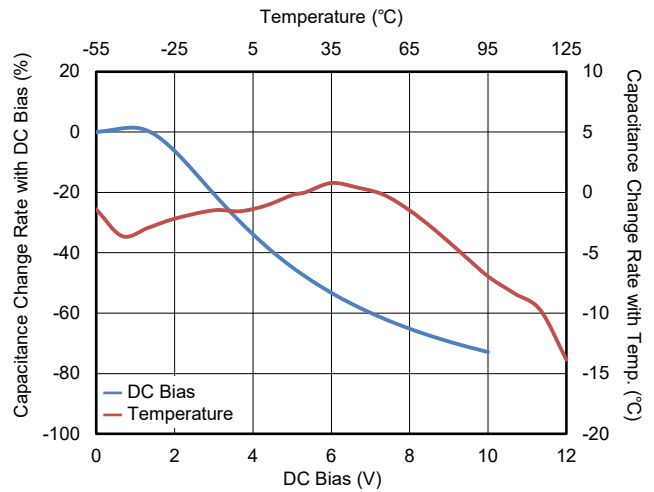

Figure 3. Capacitance vs. DC Bias and Temperature Characteristics

The SGM2232AxQ requires a minimum effective capacitance of 1.5µF for C_{OUT} to ensure stability. Additionally, C_{OUT} with larger capacitance and lower ESR will help increase the high frequency PSRR and improve the load transient response.

Under-Voltage Lockout (UVLO)

The UVLO circuit monitors the input voltage to prevent the device from turning on before V_{IN} rises above the V_{UVLO} threshold. The UVLO circuit responds quickly to glitches on the IN pin and attempts to disable the output of the device if any of these rails collapses. The local input capacitance prevents severe brownouts in most applications.

Reverse Current Protection

The power transistor has an inherent body diode. This body diode will be forward biased when V_{OUT} > (V_{IN} + 0.3V). When V_{OUT} > (V_{IN} + 0.3V), the reverse current flowing from the OUT pin to the IN pin will damage the SGM2232AxQ. If V_{OUT} > (V_{IN} + 0.3V) event would happen in system, one external Schottky diode will be added between OUT pin and IN pin in circuit design to protect the SGM2232AxQ.

Output Current Limit Protection

When overload events happen, the output current is internally limited to 345mA (TYP). When the OUT pin is shorted to ground, the output current is internally limited to 285mA (TYP).

APPLICATION INFORMATION (continued)

Thermal Shutdown

When the die temperature exceeds the threshold value of thermal shutdown, the SGM2232AxQ will be in shutdown state and it will remain in this state until the die temperature decreases to +150°C.

Power Dissipation (P_D)

Power dissipation (P_D) of the SGM2232AxQ can be calculated by the equation P_D = (V_{IN} - V_{OUT}) × I_{OUT}. The maximum allowable power dissipation (P_{D(MAX)}) of the SGM2232AxQ is affected by many factors, including the difference between junction temperature and

ambient temperature (T_{J(MAX)} - T_A), package thermal resistance from the junction to the ambient environment (θ_{JA}), the rate of ambient airflow and PCB layout. P_{D(MAX)} can be approximated by the following equation:

$$P_{D(MAX)} = (T_{J(MAX)} - T_A) / \theta_{JA} \quad (1)$$

Layout Guidelines

To get good PSRR, low output noise and high transient response performance, the input and output bypass capacitors must be placed as close as possible to the IN pin and OUT pin separately.

REVISION HISTORY

NOTE: Page numbers for previous revisions may differ from page numbers in the current version.

Changes from Original to REV.A (APRIL 2026)	Page
Changed from product preview to production data.....	All

PACKAGE INFORMATION

PACKAGE OUTLINE DIMENSIONS

SOT-223-3

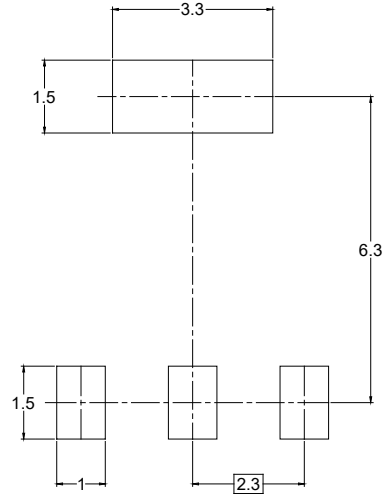
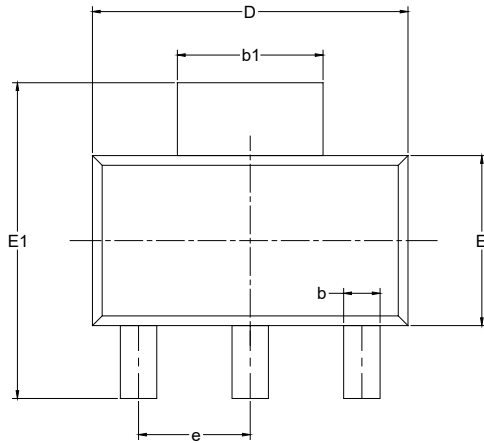

RECOMMENDED LAND PATTERN (Unit: mm)

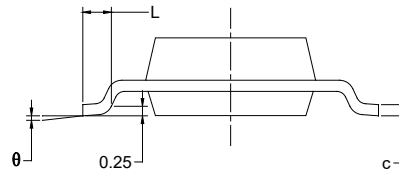
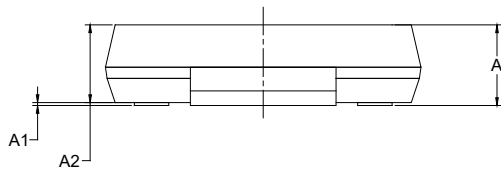

Symbol	Dimensions In Millimeters		Dimensions In Inches	
	MIN	MAX	MIN	MAX
A		1.800		0.071
A1	0.020	0.100	0.001	0.004
A2	1.500	1.700	0.059	0.067
b	0.660	0.840	0.026	0.033
b1	2.900	3.100	0.114	0.122
c	0.230	0.350	0.009	0.014
D	6.300	6.700	0.248	0.264
E	3.300	3.700	0.130	0.146
E1	6.700	7.300	0.264	0.287
e	2.300 BSC		0.091 BSC	
L	0.750		0.030	
θ	0°	10°	0°	10°

NOTES:

1. Body dimensions do not include mold flash or protrusion.
2. This drawing is subject to change without notice.

PACKAGE INFORMATION

PACKAGE OUTLINE DIMENSIONS

SOT-23-5

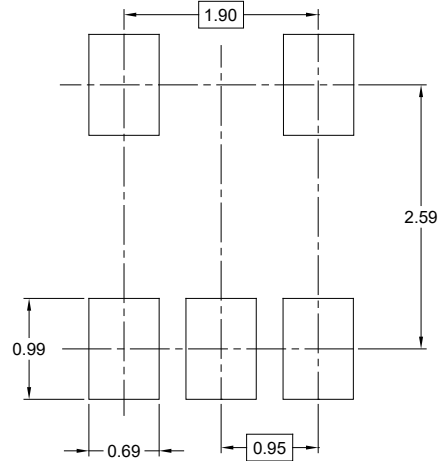
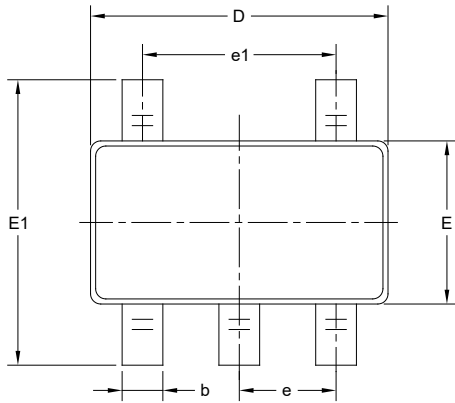

RECOMMENDED LAND PATTERN (Unit: mm)

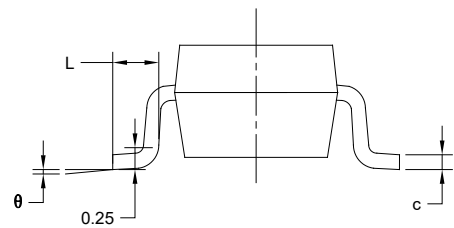
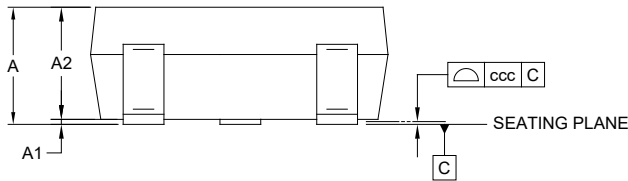

Symbol	Dimensions In Millimeters		
	MIN	NOM	MAX
A	-	-	1.450
A1	0.000	-	0.150
A2	0.900	-	1.300
b	0.300	-	0.500
c	0.080	-	0.220
D	2.750	-	3.050
E	1.450	-	1.750
E1	2.600	-	3.000
e	0.950 BSC		
e1	1.900 BSC		
L	0.300	-	0.600
θ	0°	-	8°
ccc	0.100		

NOTES:

1. This drawing is subject to change without notice.
2. The dimensions do not include mold flashes, protrusions or gate burrs.
3. Reference JEDEC MO-178.

PACKAGE INFORMATION

TAPE AND REEL INFORMATION

REEL DIMENSIONS

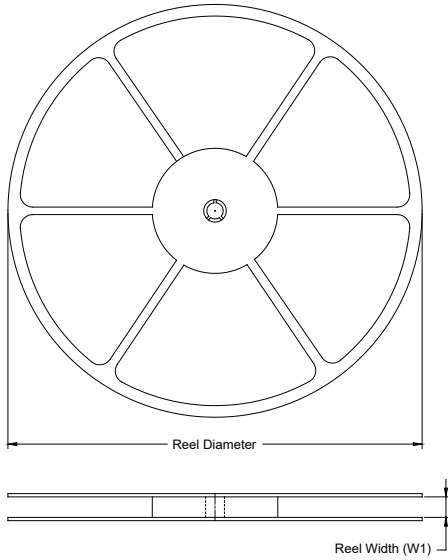

TAPE DIMENSIONS

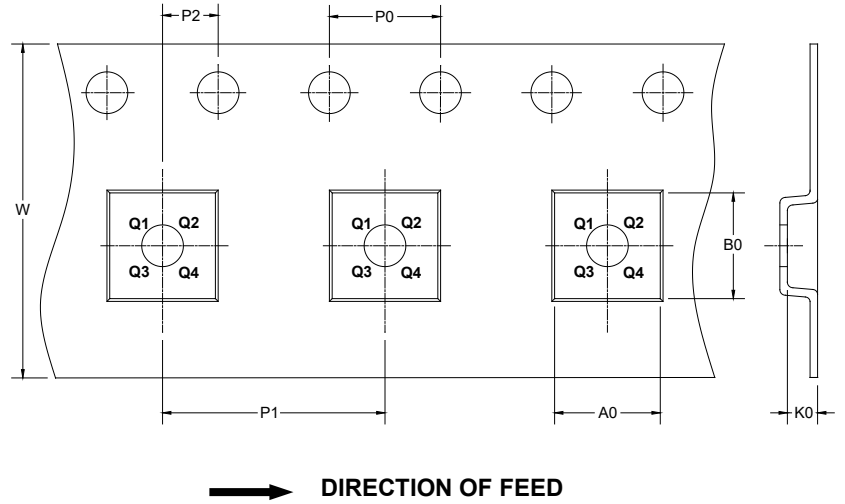

NOTE: The picture is only for reference. Please make the object as the standard.

KEY PARAMETER LIST OF TAPE AND REEL

Package Type	Reel Diameter	Reel Width W1 (mm)	A0 (mm)	B0 (mm)	K0 (mm)	P0 (mm)	P1 (mm)	P2 (mm)	W (mm)	Pin1 Quadrant
SOT-223-3	13"	12.4	6.55	7.25	1.90	4.0	8.0	2.0	12.0	Q3
SOT-23-5	7"	9.5	3.20	3.20	1.40	4.0	4.0	2.0	8.0	Q3

DD0001

PACKAGE INFORMATION

CARTON BOX DIMENSIONS

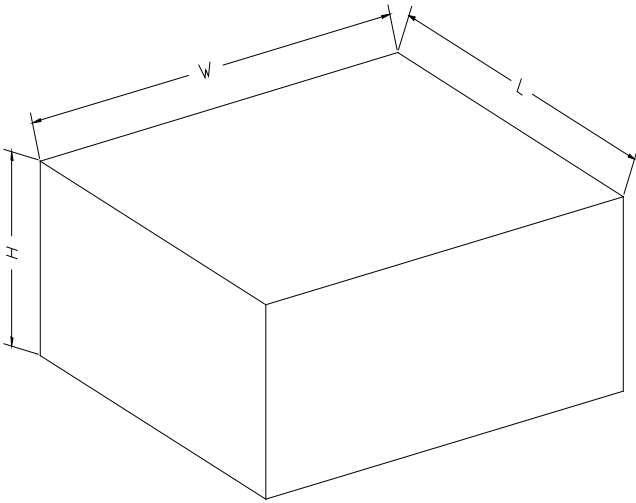

NOTE: The picture is only for reference. Please make the object as the standard.

KEY PARAMETER LIST OF CARTON BOX

Reel Type	Length (mm)	Width (mm)	Height (mm)	Pizza/Carton
7" (Option)	368	227	224	8
7"	442	410	224	18
13"	386	280	370	5

DD0002